



All-In-One ESS

Off-grid

Wall Mounted Energy Storage System

LiFePO₄ Battery + Smart Inverter

LPWONE 1.28KWh + 1KW

LPWONE 2.25KWh + 3KW

LPWONE 5.12KWh + 5KW

LPWONE 10.24KWh + 5KW



User Manual

1. Information

1.1 System Introduction

LPWONW ESS with wheels (including Pack 1.28 up 10.24KWh and 1KW up 5KW Inverter) can be used in DC coupled systems (mainly newly installed), Ac coupling system (mainly transformation) and off-grid system (mainly transformation, photovoltaic capacity increase), the scheme is as follows:

Solution	Configuration	
	Inverter	Battery
LPWONE 1.2KWh+1KW	1KW	1.28KWh
LPWONE 2.56KWh+3KW	3KW	2.56KWh
LPWONE 5.12KWh+5KW	5KW	5.12KWh
LPWONE 10.24KWh+5KW	5KW	10.24KWh

1.2 Application

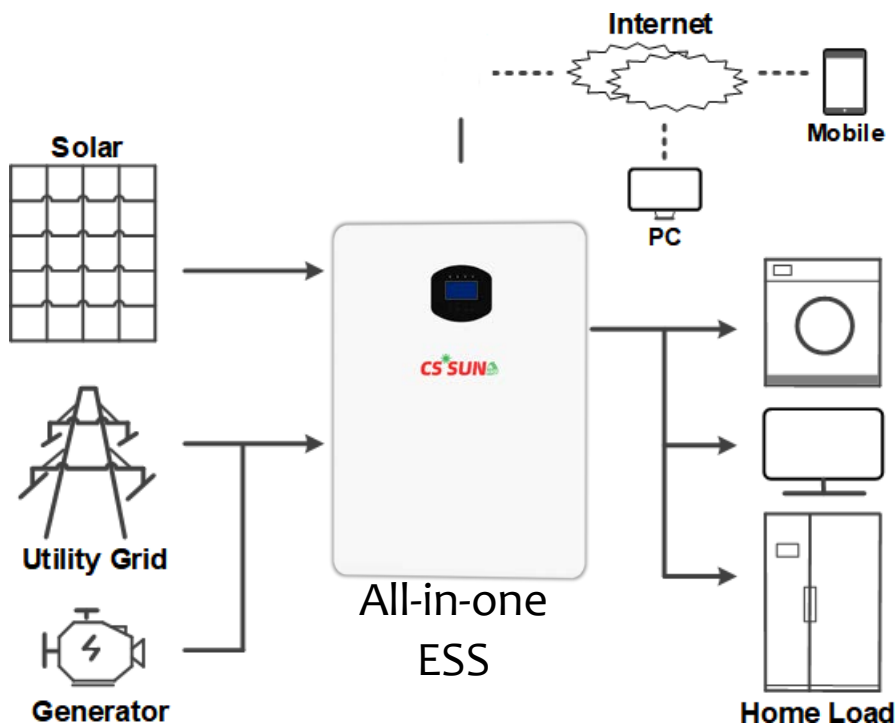

ESS Figure1 Working Diagram

1.3 Safety Instructions



1.3.1 This sign indicates a hazardous situation which, if not avoided, could result in death or serious injury.



1.3.2 The All-In-One must not be touched or put into service until 5 minutes after it has been switched off or disconnected to prevent an electric shock or injury.



1.3.3 This sign shows danger of hot surface.



1.3.4 Refer to the operating instructions.

1.3.5. Setting of Warning Sign for Safety

During instruction, maintenance and repair, follow the instructions below to prevent non-specialist personnel from causing misuse or accident:

- ◆ Obvious signs should be placed at front switch and rear-level switch to prevent accidents caused by false switching.
- ◆ Warning signs or tapes should be set near operating areas.
- ◆ The system must be reinstalled after maintenance or operation.

1.3.6 Measuring Equipment

To ensure the electrical parameters to match requirements, related measuring equipment are required when the system is being connected or tested.

Ensure that the connection and use matched specification to prevent electric arcs or shocks.

1.3.7 Moisture Protection

It is very likely that moisture may cause damages to the system. Repair or maintaining activities in wet weather should be avoided or limited.

1.3.8 Operation After Power Failure

The battery system is part of the energy storage system which stores life-threatening high voltage even when the DC side is switched off. Touching the battery outlets is strictly prohibited. The inverter can keep a life-threatening voltage even after disconnecting it from the DC and / or AC side.

Therefore, for safety reasons, it must be tested with a properly calibrated voltage tester before an installer works on the equipment.

1.4 Battery Safety Datasheet

1.4.1 Hazard Information

Classification of the hazardous chemical:

Exempt from classification according to Australian WHS regulations. Other hazards:

This product is a Lithium Iron Phosphate Battery with certified compliance under the UN Recommendations on Transport of Dangerous Goods, Manual of Tests and Criteria, Part III, subsection 38.3. For the battery cell, chemical materials are stored in a hermetically sealed metal case, designed to withstand temperatures and pressures encountered during normal use. As a result, during normal use, there is no physical danger of ignition or explosion and chemical danger of hazardous materials' leakage. However, if the product is exposed to a fire, added mechanical shocks, decomposed, added electric stress by misuse, the gas release vent will be operated. The battery cell case will be breached at the extreme. Hazardous materials may be released.

Moreover, if heated strongly by the surrounding fire, acrid or harmful fume may be emitted.

1.4.2 Safety Datasheet

For detailed information please refer to the provided battery safety datasheet.

1.5 General Precautions

DANGER

Danger to life due to high voltages of the PV array, battery and electric shock. When exposed to sunlight, the PV array generates dangerous DC voltage which will be present in the DC conductors and the live

components of the inverter. Touching the DC conductors or the live components can lead to lethal electric shocks. If you disconnect the DC connectors from the system under load, an electric arc may occur leading to electric shock and burns.

- ◆ Do not touch uninsulated cable ends.
- ◆ Do not touch the DC conductors.
- ◆ Do not open the inverter and battery.
- ◆ Do not wipe the system with damp cloth.
- ◆ Have the system installed and commissioned by qualified people with the appropriate skills only.
- ◆ Prior to performing any work on the inverter or the battery pack, disconnect the inverter from all voltage sources as described in this document.

WARNING

Risk of chemical burns from electrolyte or toxic gases. During standard operation, no electrolyte shall leak from the battery pack and no toxic gases shall form. Despite careful construction, if the Battery Pack is damaged or a fault occurs, it is possible that electrolyte may be leaked or toxic gases formed.

- ◆ Do not install the system in any environment of temperature below -10°C or over 50°C and in which humidity is over 90%.
- ◆ Do not touch the system with wet hands.
- ◆ Do not put any heavy objects on top of the system. Do not damage the system with sharp objects.
- ◆ Do not install or operate the system in potentially explosive atmospheres or areas of high humidity.
- ◆ Do not mount the inverter and the battery pack in areas containing highly flammable materials or gases.

- ◆ If moisture has penetrated the system (e.g. due to a damaged enclosure), do not install or operate the system.
- ◆ Do not move the system when it is already connected with battery modules. Secure the system to prevent tipping with restraining straps in your vehicle.
- ◆ The transportation of product must be made by the manufacturer or an instructed personal. These instructions shall be recorded and repeated.
- ◆ A certified ABC fire extinguisher with minimum capacity of 2kg must be carried along when transporting.
- ◆ It is totally prohibited to smoke in the vehicle as well as close to the vehicle when loading and unloading.
- ◆ For the exchange of a battery module, please request for new hazardous goods packaging if needed, pack it and let it be picked up by the suppliers.
- ◆ In case of contact with electrolyte, rinse the affected areas immediately with water and consult a doctor without delay.



CAUTION:

Risk of injury through lifting or dropping the system. The inverter and battery are heavy. There is risk of injury if the inverter or battery is lifted incorrectly or dropped during transport or when attaching to or removing from the wall.

- ◆ Lifting and transporting the inverter and battery must be carried out by more than 2 people.

1.6 Parts List

Check the following parts list to ensure it is complete.

factory delivers a total system separately on site to client, this consists of:

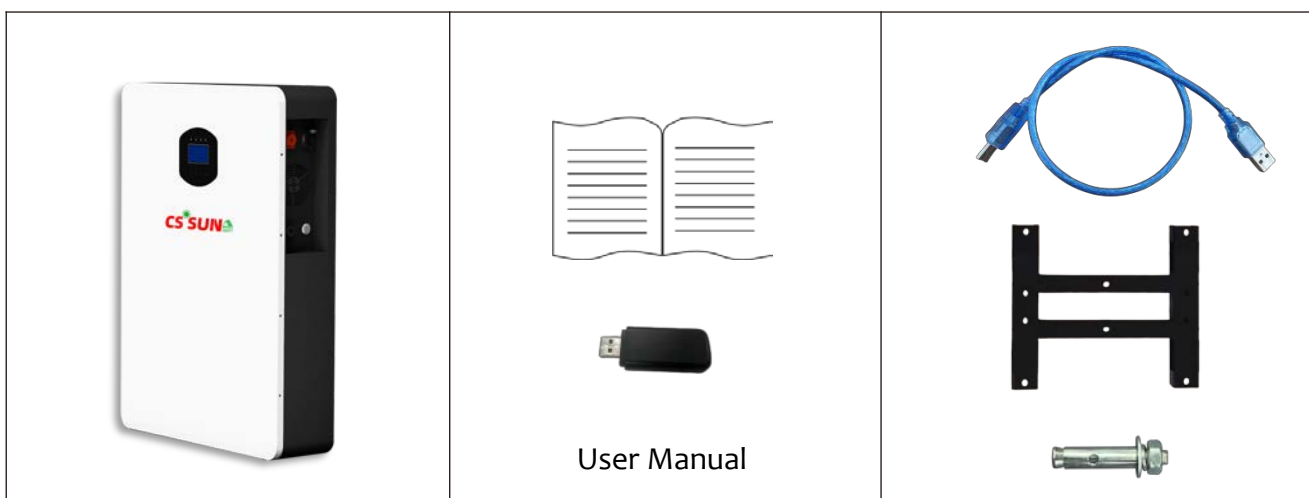

1.7 Specifications

Item	Model	1.28KWh+1KW	2.56KWh+3KW	5.12KWh+5KW	10.24KWh+5KW
Battery Module	Voltage	12.8V	25.6V	51.2V	51.2V
	Battery capacity	100Ah	100Ah	100Ah	200Ah
	Charge voltage	14.6V	29.2V	58.4V	58.4V
	Discharge cut- off voltage	10V	22V	42V	40V
	Charge current	50A	50A	50A	50A
	Max charge current	100A	100A	100A	100A
	Discharge current	50A	50A	100A	100A
	Max discharge current	100A	120A	100A	100A
	Max peak current	150A	150A	120A	120A
Inverter	Power	1KW	3KW	5KW	5KW
	Output Voltage	230VAC	230VAC	230VAC	230VAC
	Frequency	50Hz/60Hz	50Hz/60Hz	50Hz/60Hz	50Hz/60Hz
	input power (PV)	1KW	3KW	5KW	5KW
	Input voltage range (PV)	20~150VDC	40~450VDC	120~450VDC	120~450VDC
	Communication connect port	/	/	R485/CAN	R485/CAN
Parameter	Protection Degree	IP21	IP21	IP21	IP21
	Material/Colour	Metal	Metal	Metal	Metal
		White+Black	White+Black	White+Black	White+Black
	Size	460*310*220mm	510*370*225mm	450*270*610mm	485*270*770mm
	Weight	17.7Kg	29.0Kg	58KG	105KG
	Temperature range	-10°C-50°C	-10°C-50°C	-10°C-50°C	-10°C-50°C

1.8 Liability Limitation

Any product damage or property loss caused by the following conditions, factory does not assume any direct or indirect liability.

Product modified, design changed or parts replaced without factory authorization;

Changes, repair attempts and erasing of series number or seals by non factory technician;

System design and installation are not in compliance with standards and regulations;

Fail to comply with the local safety regulations (VDE for DE, SAA for AU);
Transport damage (including painting scratch caused by rubbing inside packaging during shipping). A claim should be made directly to shipping or insurance company in this case as soon as the container/packaging is unloaded and such damage is identified;
Fail to follow any/all of the user manual, the installation guide and the maintenance regulations;
Improper use or misuse of the device;
Insufficient ventilation of the device;
The maintenance procedures relating to the product have not been followed to an acceptable standard;
Force majeure (violent or stormy weather, lightning, overvoltage, fire etc.); Damages caused by any external factors.

1.9 Installation

This Manual introduces the basic steps to install and set up product



NOTE:

Please be cautious unpacking the battery, otherwise components could be damaged.

1.10 Installation Site and Environment

General

This energy storage system is indoor version and can be installed in an indoor location.

When product systems are installed in a room, product must not be hampered by the structure of the building, the furnishings and equipment of the room.

The product is naturally ventilated. The location should therefore be clean, dry and adequately ventilated. The mounting location must allow free access to the unit for installation and maintenance purposes, and the system panels must not be blocked.

The following locations are not allowed for installation:

habitable rooms;

ceiling cavities or wall cavities;

on roofs that are not specifically considered suitable;

access / exit areas or under stairs / access walkways;

where the freezing point can be reached, such as garages, carports or other places as well as wet rooms (environmental category 2);

locations with humidity and condensation over 90%;

places where salty and humid air can penetrate;

seismic areas - additional security measures are required;

Sites with altitude below 2000m;

places with an explosive atmosphere;

locations with direct sunlight or a large change in the ambient temperature;

places with flammable materials or gases or an explosive atmosphere.

2.Product Introduction

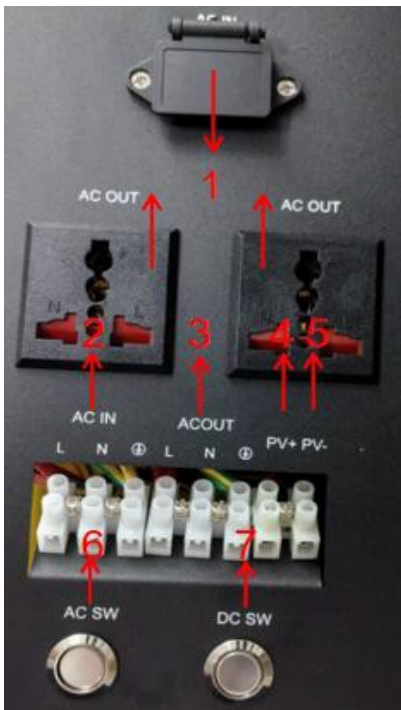

NO	NAME	Silk-SCREEN	REMARK
1	AC OUT	AC OUT	AC OUTPUT
2	AC IN	AC IN	AC input
3	AC OUT	AC OUT	AC OUTPUT
4	PV+	PV+	PV+
5	PV-	PV-	PV-
6	SW	SW	AC switch
7	SW	SW	AC switch
8	SW	SW	DC switch
9	DC	DC	/

2.1 Installation

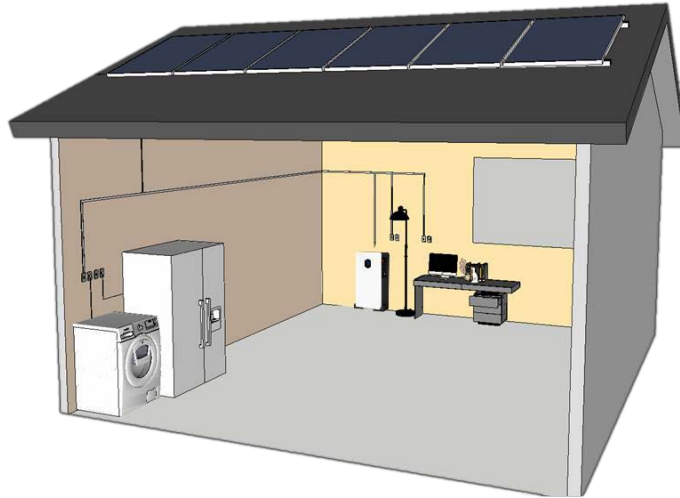

Household off-grid application



NOTE: First turn on the battery switch, then turn on the inverter switch.



NOTE: Recommended AC circuit breaker rating is 22A.



STATEMENT: The method of anti-islanding protection is Method(c)

3. System Operation

3.1 Switch On

When turning on the system, it is very important to follow the steps below to prevent damage to the system .

WARNING: Please check the installation again before turning on the system .



- Step 1: Press the DC switch button, then press the AC switch button, and the display will light up
- Step 2: Turn on the external PV switch. (If there is a PV external switch)
- Step 3: Turn on the external grid switch. (If there is a external grid switch)
- Step 4: If backup load is applied, turn on the external Backup switch.

	<p>NOTE: the Backup switch is only used when a backup load is applied.</p>
---	---

3.2 Switch Off

- Step 1: Press the AC switch button, then press the DC switch button until the display is
- Step 2: off. Turn off the external grid switch.
- Step 3: If backup load is applied, turn off the external backup
- Step 4: switch. Turn off the external PV switch on the cable box.

3.3 AC Input/Output Connection

CAUTION: Before connecting to AC input power source, please install a separate AC breaker between inverter and AC input power source. This will ensure the inverter can be securely disconnected during maintenance and fully protected from over current of AC input. The recommended spec of AC breaker is 32A for 1KW/3KW.

CAUTION: There are two terminal blocks with ‘IN’ and ‘OUT’ markings. Please do NOT mis-connect input and output connectors.

WARNING: All wiring must be performed by a qualified personnel.

WARNING: It’s very important for system safety and efficient operation to use appropriate cable for AC input connection. To reduce risk of injury, please use the proper recommended cable size as below.

Suggested cable requirement for AC wires

Model	Gauge	Torque Value
1KW	1*16AWG	0.5-0.6 Nm
3KW	1*12AWG	1.2-1.6 Nm
5KW	1*8AWG	1.4-1.6 Nm

Please follow below steps to implement AC input/output connection:

Before making AC input/output connection, be sure to open DC protector or disconnecter first. Remove insulation sleeve 10mm for six conductors. And shorten phase L and neutral conductor N 3 mm. Insert AC input/output wires according to polarities indicated on terminal and tighten the terminal screws.

Be sure to connect PE protective conductor  first.

- ⊕ → Ground (yellow)
- L → LINE (red)
- N → Neutral (black)

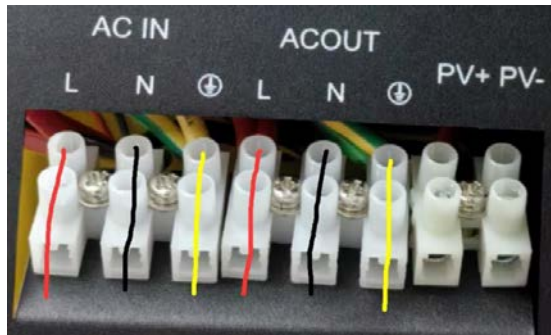

Connect the corresponding cable to the port according to the identifier, Make sure the wires are securely connected.

	WARNING: Be sure that AC power source is disconnected before attempting to hardwire it to the unit.
--	---

CAUTION: Important

Be sure to connect AC wires with correct polarity. If L and N wires are connected reversely, it may cause utility short-circuited when these inverters are worked in parallel operation.

CAUTION: Appliances such as air conditioner are required at least 2~3 minutes to restart because it's required to have enough time to balance refrigerant gas inside of circuits. If a power shortage occurs and recovers in a short time, it will cause damage to your connected appliances. To prevent this kind of damage, please check with manufacturer of air conditioner that if it's equipped with time-delay function before installation. Otherwise, this off grid solar inverter will trig overload fault and cut off output to protect your appliance but sometimes it still causes internal damage to the air conditioner.

3.4 PV Connection

CAUTION: Before connecting to PV modules, please install separately a DC circuit breaker between inverter and PV modules.

WARNING: All wiring must be performed by a qualified personnel.

WARNING: It's very important for system safety and efficient operation to use appropriate cable for PV module connection. To reduce risk of injury, please use the proper recommended cable size as below.

Typical Amperage	Gauge	Torque Value
50A	1*12AWG	1.2-1.6 Nm

PV Module Selection:

When selecting proper PV modules, please be sure to consider below parameters:

1. Open circuit Voltage (Voc) of PV modules not exceeds max. PV array open circuit voltage of inverter.
2. Open circuit Voltage (Voc) of PV modules should be higher than min. battery voltage.

Inverter Model	1KW	3KW	5KW
Max. PV Array Open Circuit Voltage	150Vdc	450Vdc	450Vdc
PV Array MPPT Voltage Range	20Vdc~150Vdc	40Vdc~450Vdc	40Vdc~450Vdc

Please follow below steps to implement PV module connection:

Remove insulation sleeve 10 mm for positive and negative conductors.

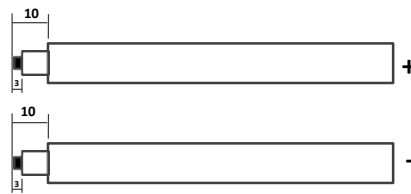

Step 1: Check the input voltage of PV array modules. This system is applied with One strings of PV array. Please make sure that the maximum current load of each PV input connector is 18 A .

CAUTION: Exceeding the maximum input voltage can destroy the unit!! Check the system before wire connection.

Step 2: Disconnect the circuit breaker and switch off the DC switch.

Step 3: Insert PV+/PV- according to the polarity indicated on the terminal, and tighten the terminal screw.



Make sure the wires are securely connected.

3.7 Emergency Procedure

When the energy storage system appears to be running abnormally, you can turn off the grid-connected main switch that directly feeding the BESS , and turn off all load switches within the BESS ,turn off the battery switch at the same time. To prevent a potentially fatal personal injury, if you want to repair or open the machine after the power is switched off,please measure the voltage at the input terminals with a suitably calibrated voltage tester.Before working on this equipment, please confirm that there is no grid electric supply to the BESS! The upper cover plate cannot be opened until the DC-link capacitance inside the battery modules discharges completely about 15 minutes later.

3.7.1 Emergency Handling Plan

- 1.Disconnect the AC breaker.
2. Check the control power supply. If it is OK, return the power supply to find out the reason.
- 3.Please record every detail related to the fault, so Factory can analyse and solve the fault. Any operation of equipment during a fault is strictly forbidden, please contact Factory as soon as possible.
- 4.As battery cells contain a little Oxygen inside and all cells have got explosion-proof valves,explosion hardly happens.
- 5.When the indicator light on the battery shows a red fault, check the fault type through the communication protocol, and contact our after-sales service personnel for advice.

3.7.2 Hazards

If the battery pack leaks electrolyte, avoid contact with the leaking liquid or gas. If one is exposed to the leaked substance, immediately perform the actions described below:

Inhalation: Evacuate the contaminated area, and seek medical attention.

Eye contact: Rinse eyes with running water for 5 minutes, and seek medical attention.

Contact with skin: Wash the affected area thoroughly with soap and water, and seek medical attention. Ingestion: Induce vomiting and seek medical attention.

3.7.3 Fire

If a fire breaks out in the place where the battery pack is installed, perform the following countermeasures:

Fire extinguishing media

During normal operation, no respirator is required. Burning batteries can not be extinguished with a regular fire extinguisher, this requires special fire extinguishers such as the Novec 1230, the FM-200 or a dioxin extinguisher. If the fire is not from a battery, normal ABC fire extinguishers can be used for extinguishing.

Fire -fighting instructions

1. If fire occurs when charging batteries, if it is safe to do so, disconnect the battery pack circuit breaker to shut off the power to charge.
2. If the battery pack is not on fire yet, extinguish the fire before the battery pack catches fire.
3. If the battery pack is on fire, do not try to extinguish but evacuate people immediately.



NOTE: There may be a possible explosion when batteries are heated above 150 °C. When the battery pack is burning, it leaks poisonous gases. Do not approach.

Effective ways to deal with accidents

Battery in dry environment: Place damaged battery into a segregated place and call local fire department or service engineer.

Battery in wet environment: Stay out of the water and don't touch anything if any part of the battery,

inverter, or wiring is submerged.

Do not use a submerged battery again and contact the service engineer.

4.EMS Introduction And Set Up

4.1 LCD Display Icons

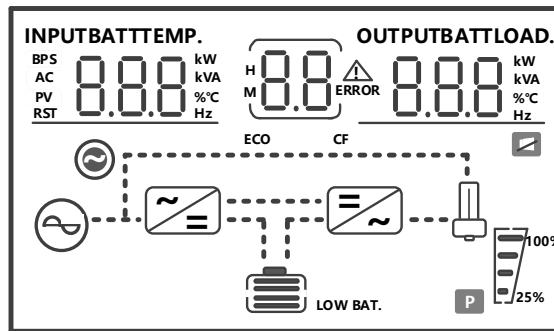

Function Buttons

Button	Description
ESC	To exit setting mode
UP	To go to previous selection
DOWN	To go to next selection
ENTER	To confirm the selection in setting mode or enter setting mode

5. Routine Maintenance

5.1 Maintenance Plan

- ◆ Check if wire connections are loose.
- ◆ Check if cables are aged/damaged.
- ◆ Check if cable insulating ribbon drops.
- ◆ Check if cable terminal is loose, any overheat sign.
- ◆ Check if ground connection is good.

5.1.1 Operating Environment

(Every six months)

Carefully observe whether the battery system equipment is ineffective or damaged; When the system is running, listen to any part of the system for abnormal noise;

Check whether the voltage, temperature and other parameters of the battery and other equipment parameters are normal during system operation;

5.2.2 Equipment Cleaning

(Every six months to one year, depending on the site environment and dust content, etc.)Ensure that the ground is clean and tidy, keep the maintenance access route unblocked, and ensure that the warning and guiding signs are clear and intact.

Monitor the temperature of the battery module and clean the battery module if necessary.

5.1.3 Cable, Terminal and Equipment Inspection

(Every six months to one year)

- ◆ Check if the cable connections are loose.
- ◆ Check whether the cables are aged / damaged.
- ◆ Check whether the cable tie of the cable has fallen off.
- ◆ Check if the cable terminal screws are loose and the terminal position has any signs of overheating.
- ◆ Check whether the management system of the system equipment, monitoring system and other related equipment are invalid or damaged.
- ◆ Check that the grounding of the equipment is good and the grounding resistance is less than 10 ohms.

5.2 Notes

After the equipment is out of operation, please pay attention to following notes while maintaining :

- ◆ Related safety standards and specifications should be followed in operation and maintenance.
- ◆ Disconnect all the electrical connections so that the equipment would not be powered on.
- ◆ Wait at least 5 minutes after disconnection, so that the residual voltage of the capacitors drops to a safe voltage. Use a multimeter to make sure that the equipment is completely discharged.
- ◆ The equipment should be repaired by professional staff only and it is strictly forbidden for maintenance staff to open equipment modules on their own.
- ◆ Appropriate protective measures should be taken while maintaining, such as insulated gloves, shoes, and anti-noise ear plugs.
- ◆ Life is priceless. Make sure no one would get hurt first.
- ◆ In case of a deep discharge, the battery must be charged to a SOC rate of 30% to 50% if the entire system is static (ie the battery has not been charged for two weeks or more).

Please contact us in time if there are any conditions that could not be explained in the manual.

6. Quality Assurance

When product faults occur during the warranty period, factory or his partner will provide free service or replace the product with a new one.

Evidence

During the warranty period, the customer shall provide the product purchase invoice and date. In addition, the trademark on the product shall be undamaged and legible. Otherwise, factory has the right to refuse to honor the quality guarantee.

Conditions

- ◆ After replacement, unqualified products shall be processed by factory.
- ◆ The customer shall give manufacturer or his partner a reasonable period to repair the faulty device.

Exclusion of Liability

In the following circumstances, manufacturer has the right to refuse to honor the quality guarantee:

- ◆The free warranty period for the whole machine/components has expired.
- ◆The device is damaged during transport.
- ◆The device is incorrectly installed, refitted, or used.
- ◆The device operates in harsh environment, as described in this manual.
- ◆The fault or damage is caused by installation, repairs, modification, or disassembly performed by a service provider or personnel not from manufacturer or his authorized partner .
- ◆The fault or damage is caused by the use of non-standard or non-manufacturer.

components or software.

- ◆The installation and use range are beyond stipulations of relevant international standards.
- ◆The damage is caused by unexpected natural factors.

For faulty products in any of above cases, if the customer requests maintenance, paid maintenance service may be provided based on the judgment of manufacturer.