

UP Stand Movable LiFePO4 Lithium Battery Pack

LPUS48V400H
51.2V400Ah 20.5KWh
Energy Storage Solutions



LPUS Series Brief Introduce

LPUS Series UP Standing Movable lithium battery pack is a household energy storage solution that provides reliable and efficient power for homes. It features a high-capacity lithium-ion battery that stores renewable energy from solar panels or the grid, reducing energy consumption costs and ensuring constant power supply during emergencies. The battery's sleek and compact design allows for easy installation and maintenance. With its user-friendly interface, users can monitor their energy usage and optimize energy management. This product is ideal for homeowners who want to reduce their carbon footprint and gain greater control over their energy consumption while enjoying uninterrupted power supply. With the wheels it's move easily.

Long
Life

Lithium Iron
Phosphate

Deep
Cycle



Applications

- BTS Stations, Telecom System
- Internet data center(IDC)
- Solar Energy/Off-Grid System
- Access net work system
- UPS System, EPS System
- Terminal of FTTX
- Indoor distribution system

Dimensions & Weight

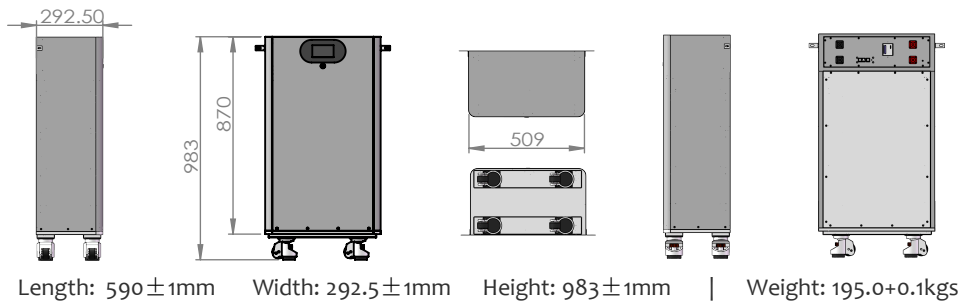

Technical Specifications

Electrical Characteristics	Nominal Voltage	51.2V
	Nominal Capacity	400Ah
	Energy	20.5KWh
	BMS with internal cell balancing	YES
	Cycle Life	> 6000cycles 800%DOD
	Months Self Discharge	< 3%
	Efficiency of Charge	100%@0.2C
	Efficiency of Discharge	96~99%@0.5C
Standard Charge	Charge Voltage	57.6V ± 0.2
	Charge Mode	0.2C to 57.6V, then 57.6V, charge current to 0.02C(CC/CV)
	Charge Current	100A
	Max. Charge Current	200A
	Charge Cut-off Voltage	57.6V ± 0.2
Standard Discharge	Continuous Current	100A
	Max continuous discharge current	200A
	Discharge Cut-off Voltage	43.2V ± 0.1
Environmental	Charge Temperature	0 °C to 45 °C (32F to 113F) @60 ± 25% Relative Humidity
	Discharge Temperature	-20 °C to 60 °C (-4F to 140F) @60 ± 25% Relative Humidity
	Storage Temperature	0 °C to 40 °C (32F to 104F) @60 ± 25% Relative Humidity
	Water Dust Resistance	IP21
Mechanical	Cell & Method	Prismatic Cell, 16S4P
	Case	Iron
	Dimensions (in./mm.)	509*292.5*938mm/20.04*11.52*36.94Ins
	Weight (lbs./kg.)	Approx: 195kgs/429.85lbs
	Gravimetric specific energy	105.03WH/KG
	Protocol (optional)	ModBus: CAN/RS485/RS232(OPT)
	SOC (optional)	Touch LCD

Inverters Support Brands: GROWATT solis PYLONTECH MEGAREVO STUDEER Volttronic Power MUST美世乐 victron energy GOODWE

SACOLAR KSTAR科士达 invt英威腾 Schneider Electric Deye 德业 爱阳储能 IYANG SOFAR SOLAR LU POWER TEK FOX ESS SMA SRNE

BMS Specifications

- Overcharge detection function
- Over discharge detection function
- Over current detection function
- Temperature protection
- Cell Voltage balance function
- Short detection function

Performance Characteristic (Data test from 16 Series Cell)

Different Rate Discharge Curve (25°C)

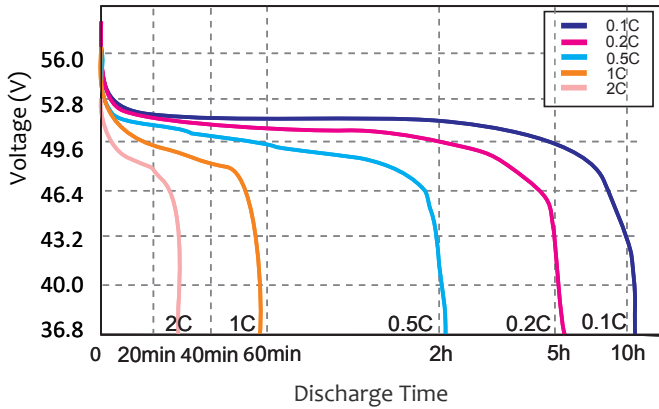

Different Temperature Discharge Curve At 0.5c

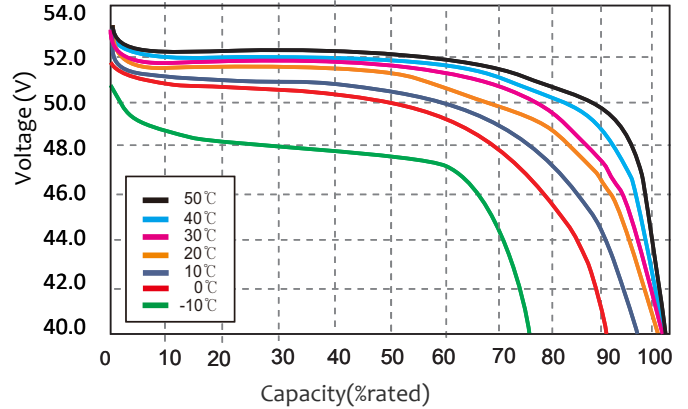

State Of Charge Curve At 0.5c (25°C)

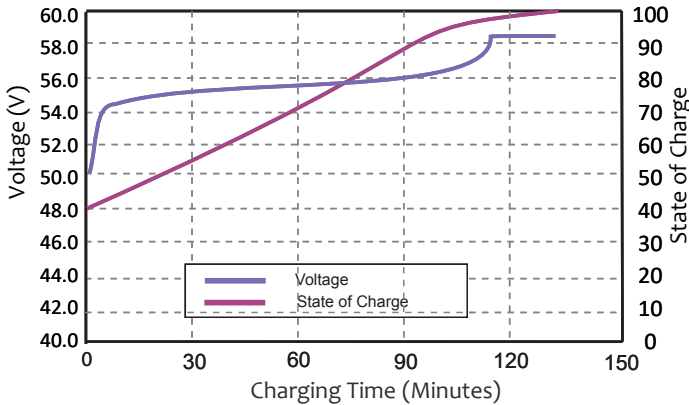

Charging Characteristics At 0.5c (25°C)

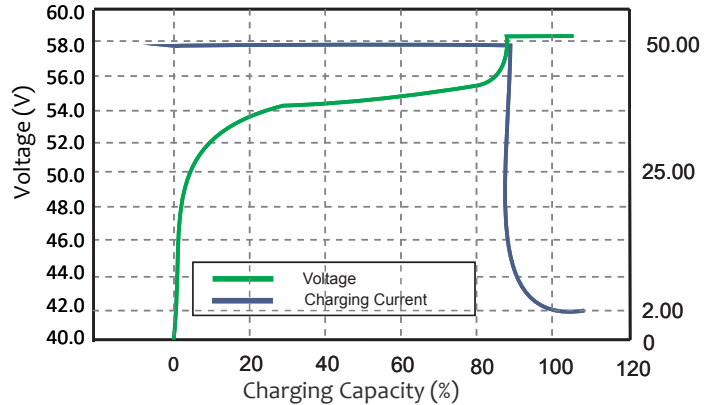

Cycle Life Curve At 1c According DoD

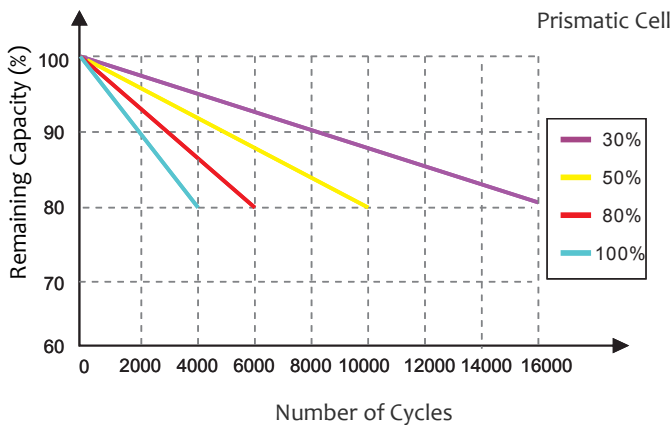

Self Discharge Characteristics Curve

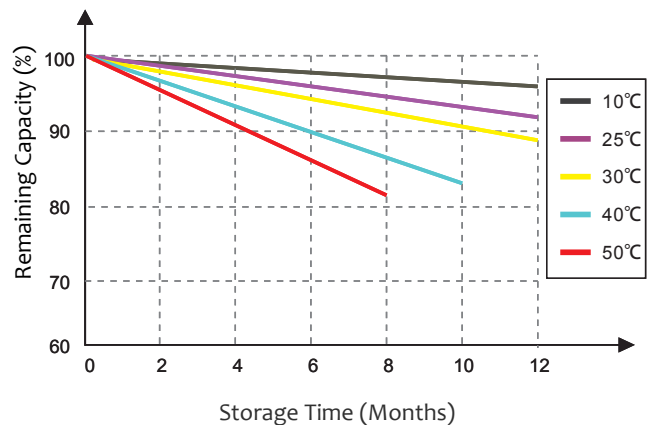

Note: All above information shall be changed without prior notice, CSSUN reserves the right to explain and update the latest information. Welcome inquiry us!
SAFETY WARNING: Use only within the allowed parameters. Do not short circuit or over-load the battery. Charge only using an approved charger designed specifically to charge this battery. Do not heat above maximum temperatures indicated. Never crush, mutilate, puncture or abuse the battery. Do not dismantle the pack or disable any of the protective devices or circuits. Do not use the battery if you suspect it may be faulty or damaged.